

**TYPICAL POST AND PANEL FIXING DETAIL**

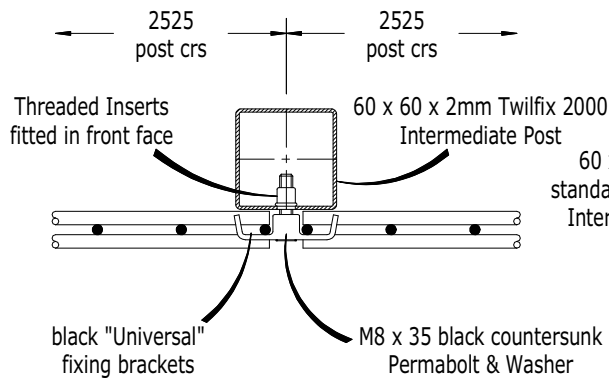

**PLAN VIEW ON INTERMEDIATE POST**

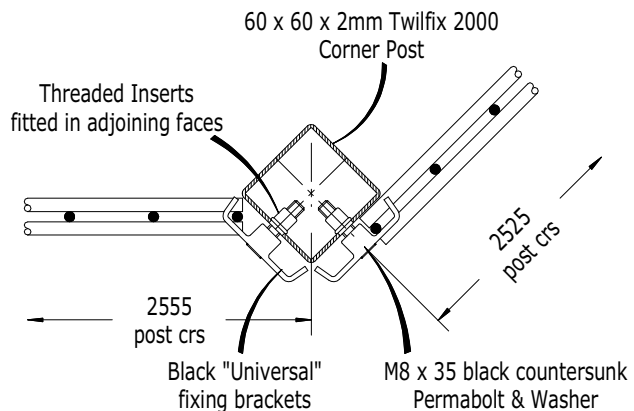

**PLAN VIEW ON OBTUSE CORNER POST**

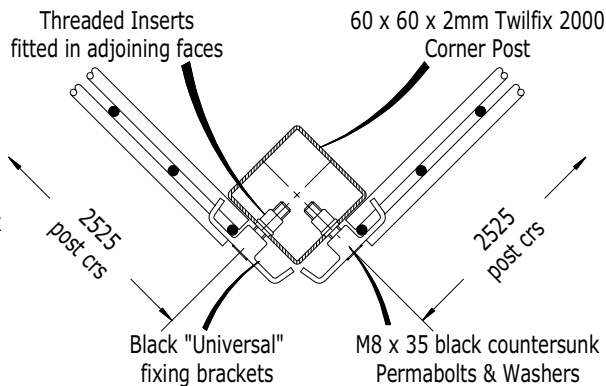

**PLAN VIEW ON 90° CORNER POST**

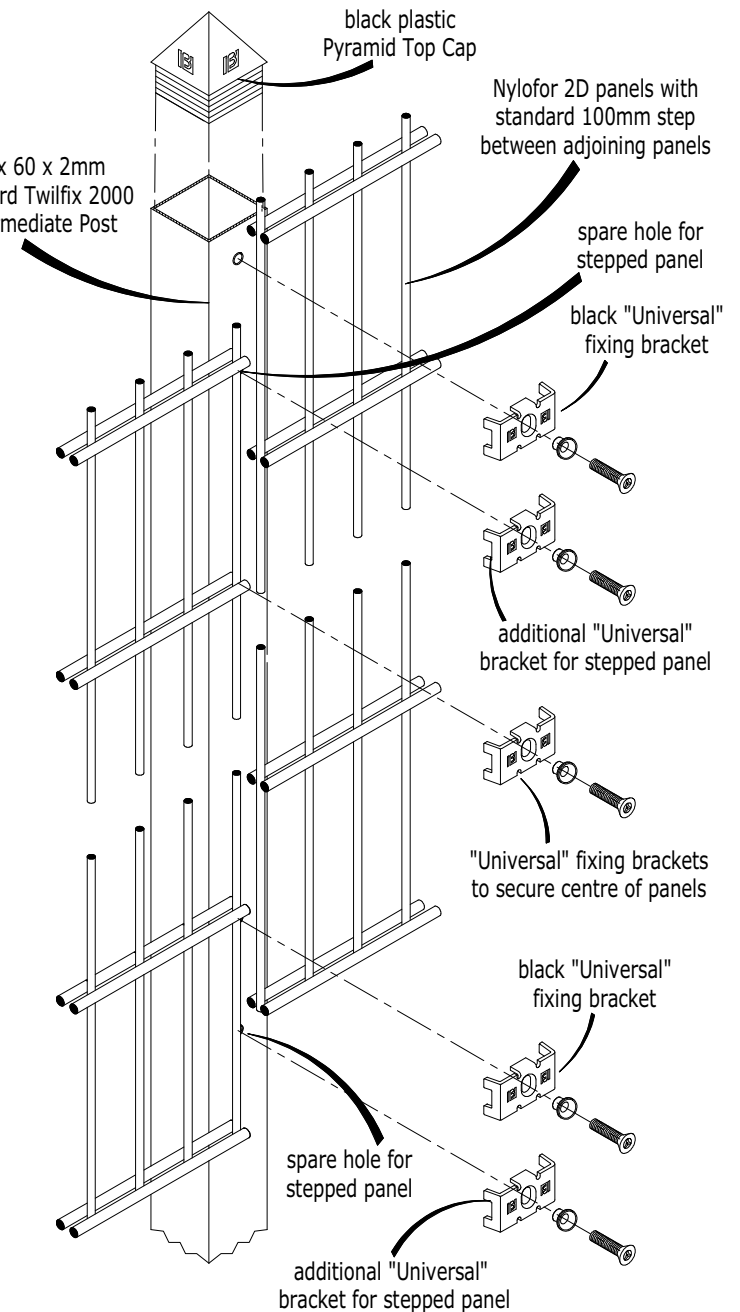

**STEPPING DETAIL FOR SLOPING GROUND**

**B BETA FENCE**

sales.sheffield@betafence.com  
www.betafence.com

Betafence Ltd - Wigan  
Woodhouse Lane  
Wigan WN6 7NS  
Phone 0870 120 3252  
Fax 0870 120 3242

Betafence Ltd. reserves the right to amend and withdraw products detailed herein, without prior notice

COPYRIGHT © 2005  
BETA FENCE LTD - SHEFFIELD - ENGLAND

**NYLOFOR 2D**

Drawn

MJH

Date

09.06.03

Drawing No :

**NY-2D-B**

REV

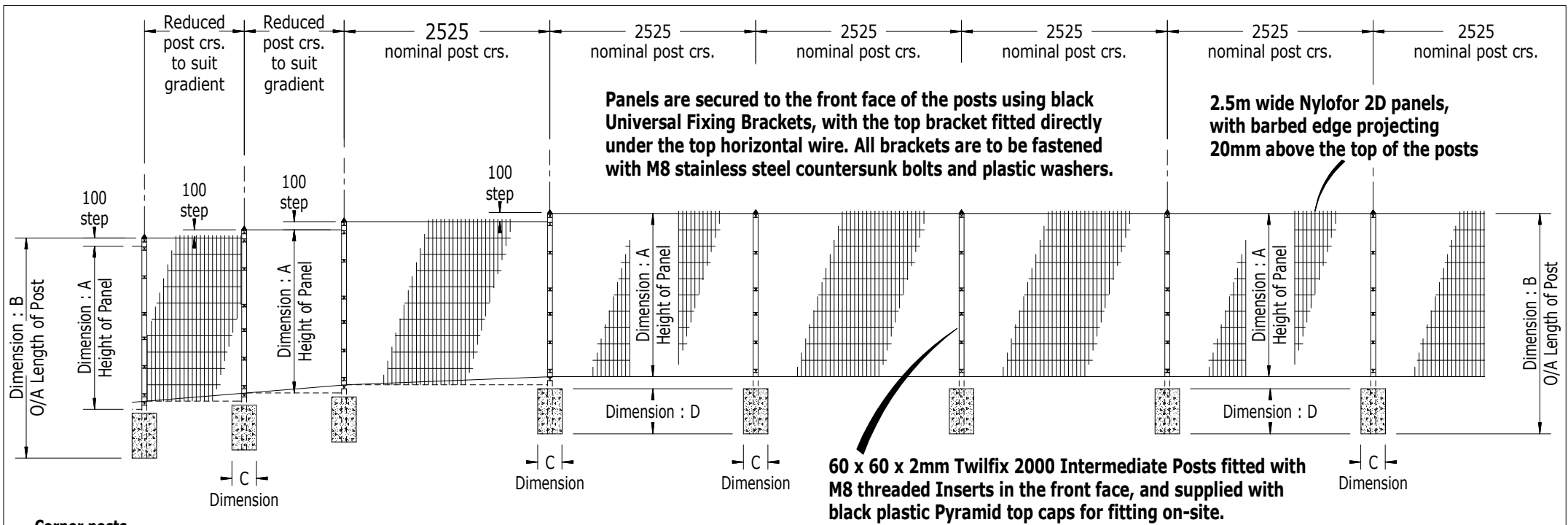

**Corner posts**

Corner posts are available for Standard 90° external and internal corners, and are also used for obtuse external and internal corners. End posts are not required.

**Gradients**

All standard Intermediate & Corner posts are fitted with 2no. additional threaded inserts at the top & bottom to facilitate 100mm steps between adjoining panels. Different gradients are achieved by reducing the post centres and width of panel to suit, ie :

- 2500 wide standard panel with 100mm step : 1 in 25 (4%) (2.3°)
- 2000 wide site-cut panel with 100mm step : 1 in 20 (5%) (2.9°)
- 1500 wide site-cut panel with 100mm step : 1 in 15 (6.6%) (3.8°)
- 1000 wide site-cut panel with 100mm step : 1 in 10 (10%) (5.7°)

Steeper slopes will require made-to-order extra long posts, manufactured with additional threaded inserts to suit the stepping required between adjoining panels to suit each gradient.

**Notes**

The preferred method of installation is : Post - Panel - Post - Panel, etc. Bolts may be installed using a Power-Driver and Power-Bit if preferred. When using hand tools, care must be taken to avoid over tightening of bolts.

Concrete Foundations must not be leaner by mass than 1 part cement to 10 parts 20mm nominal size graded aggregates, and must be thoroughly compacted prior to the initial set.

All Nylofor 2D panels are supplied to site in a standard width of 2500mm. Panels for make-up bays are to be cut to suit on site, and made good using a Zinc Etch Primer paint, followed by a top coat of Cromadex 222 polyurethane repair paint.

Dim : A Panel Height	Dim : B Length Of Post	Dim : C Size Of Found's	Dim : D Depth Of Found's	Fixings Level Ground	Fixings Sloping Ground
1030mm	1500mm	300mm	300mm	3no.	5no.
1230mm	1800mm	300mm	400mm	4no.	6no.
1830mm	2500mm	300mm	500mm	5no.	7no.
2030mm	2700mm	300mm	500mm	6no.	8no.
2430mm	3100mm	450mm	500mm	7no.	9no.

**IMPORTANT NOTE :** The Foundation sizes indicated are for "normal" ground conditions only and may require modification to suit the prevailing ground conditions on-site

The Nylofor 2D fencing system generally satisfies the requirements for Category : 1 (Genral Purpose) & Category : 2 (Security) fences as prescribed by B.S. 1722 Part : 14 - Open Mesh Steel Panel Fences